

TREVIL

Sistemi di stiratura

Trevilpres CP line

Compact cuff & collar press, easy and comfortable to use.

- Fits in little space
- With electronic board, can store different pressing modes
- Pneumatic movement
- Fan activated by photocell
- Heated polished upper buck in stainless steel; padded lower buck with suction
- Available in three versions: without boiler, with closed circuit boiler and with boiler that can feed also the Trevistar shirt finisher.



Linea Trevilpres CP

Pressa collo e polsi estremamente compatta, facile da usare ed ergonomica.

- Ingombro ridotto
- Programmatore elettronico per impostare diversi programmi di pressatura
- Funzionamento pneumatico
- Piano superiore lucido riscaldato e piano inferiore imbottito ed aspirante
- Aspirazione a partenza automatica con fotocellula
- Disponibile nelle tre versioni: senza caldaia, con caldaia a circuito chiuso e con caldaia per alimentare anche il manichino stiracamicie Trevistar.

Ligne de presses Trevilpres CP

Presse cols et poignets extrêmement compacte, facile à utiliser et ergonomique.

- Encombrement réduit
- Programmateur électronique pour mémoriser différents programmes de pressage
- Fonctionnement pneumatique
- Plateau supérieur chauffé en acier poli et plateau inférieur rembourré et aspirant
- Ventilation à départ automatique avec photocellule
- Disponible dans trois versions: sans chaudière, avec chaudière à circuit fermé et avec chaudière pour alimenter aussi le mannequin pour le repassage des chemises Trevistar.

Trevilpres CP Produktserie

Kompakte Drei-kopf Presse, leicht gebraucht und ergonomische.

- Kleinausmaß
- Steuerpanel mit mehrere Programme
- Luftarbeitsweise
- Glanzpoliert-u.beheizte Oberplatte, Saug-Unterplatte mit Polsterung
- Automatische Lüftung mit Photozelle
- Lieferbar ohne Kessel, mit Regelkreis-Kessel und mit Kessel für Trevistar Speisung.

Trevilpres CP

DATI TECNICI	TECHNICAL SPECIFICATIONS	DONEES TECHNIQUES	TECHNISCHE DATEN	DATOS TECNICOS	6311	6312	6313
Alimentazione elettrica	Power inlet	Entrée courant	Elektrischer Anschluß	Aliment. Eléctrica	230V 50Hz* 120V 60Hz*	400V 3N 50Hz*	400V 3N 50Hz*
Attacco vapore	Steam inlet	Alimentation	Dampfspeisung	Aliment. Vapor	G 1/2"	-	-
Pressione vapore	Steam pressure	Pression de	Dampfdruck	Presion vapor	500kPa, 5 bar,	-	-
Attacco ritorno cond.	Condensate return	Retour de condensant	Kondensrucklauf	Retorno de condensado	G 1/2"	-	-
Attacco aria	Air inlet	Alimentation air	Luftspeisung	Aliment. aire	G 1/4"	G 1/4"	G 1/4"
Pressione aria	Air pressure	Pression air (max)	Luftdruck (max)	Presion de aire	700kPa, 7bar,	700kPa, 7bar,	700kPa, 7bar,
Motore aspira-	Suction motor	Moteur aspirateur	Absaugung	Motor aspirante	400 W, 0.5 HP	400 W, 0.5 HP	400 W, 0.5 HP
Resistenza	Boiler element	Résist. chaudière	Kesselelement	Resist. calderín	-	6 kW	24 - 30 kW
Attacco acqua	Water inlet	Alimentation eau	Wasserspeisung	Aliment. agua	-	-	ø 16 mm
Scarico caldaia	Boiler exhaust	Decharge chau-	Kesselabflus	Descargue caldera	-	G 1/2"	G 1/2"
Pompa	Pump	Pompe	Pumpe	Bomba	-	-	0,5 kW
Dimensione macchina	Overall dimensions	Dimensions appareil	Gerät Abmessung	Dimens. aparato	108x85x138 cm 43"x33"x54"	108x85x138 cm 43"x33"x54"	108x85x138 cm 43"x33"x54"
Dimensione imballo	Shipping dimensions	Dimens. emballage	Verpackungabmess.	Dimens. embalaje	120x100x145cm 47"x39"x57"	120x100x145cm 47"x39"x57"	120x100x145cm 47"x39"x57"

* Altri a richiesta

*Others available

*Autres sur demande

*Andere auf Wunsch

*Otros a pedido

Con riserva di modifica senza preavviso - Subject to modification without notice - Sous réserve de modification sans preavis - Änderungen vorbehalten - Con reserva de modificaciò sin previo aviso

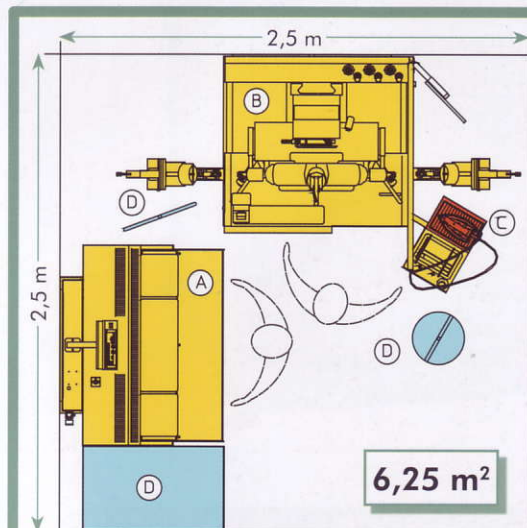

- A) Cuff & collar press
- B) Trevistar Shirt finisher
- C) Touch-up iron
- D) Shirt supports

- A) Pressa collo e polsi
- B) Manichino stircamicie Trevistar
- C) Ferro per ritocchi
- D) Supporti per camicie

- A) Presse cols et poignets
- B) Mannequin chemises Trevistar
- C) Fer
- D) Supportes pour chemises

- A) Drei-kopf Presse
- B) Trevistar Hemdenfinisher
- C) Bügeleisen
- D) Hemdenhalter



Trevistar



TREVIL